

PRESS RELEASE

February 2, 2023 || Page 1 | 7

Setting off into the third dimension

Can sophisticated metal components be 3D printed productively and reproducibly in series? Researchers from Aachen can answer this question in the affirmative: At the Fraunhofer Institute for Laser Technology ILT, they have transferred two-dimensional Extreme High-speed Laser Material Deposition EHLA to a modified five-axis CNC system for the additive manufacturing of complex components. By extending the EHLA process to the third dimension, the institute can 3D print difficult-to-weld materials such as tool steels, titanium, aluminum and nickel-based alloys.

For decades, two laser processes have dominated the printing and coating of metal components. The dominant technology in direct industrial, metallic 3D printing is the laser-based powder bed fusion (LPBF) process patented by Fraunhofer ILT 26 years ago. Here, the laser radiation melts a small part of the base material and converts the powder into a solid layer that adheres to the base material metallurgically. In this way, a 3D component grows from the powder bed layer by layer.

Laser Material Deposition (LMD) has also proven to be an efficient surface technology of a special kind. In LMD, a molten pool is formed on the component surface, into which the filler material, wire or powder, is continuously introduced. This pool melts both the substrate and the filler material, resulting in a metallurgical bond between the layer and the component substrate.

Salvaging expensive components

The economic potential lies, on the one hand, in the possibility of upgrading basic components with a functional layer or carrying out local, additive component modifications. The second important area of application for LMD is in repair, i.e. salvaging expensive components, e.g. from the aerospace industry or toolmaking. Worn or defective components can be made fully functional again after local cladding using LMD and, thus, no longer have to be scrapped.

LMD and LPBF have become indispensable for metal-based additive manufacturing since they have process-specific advantages: LMD is attractive thanks to its high productivity while LPBF can be used for 3D printing of extremely filigree and complex components. Fraunhofer ILT and the Chair for Digital Additive Production DAP at RWTH Aachen University broke completely new ground in 2012 with the development

Press contact

Petra Nolis M.A. | Head of the Communications Group | Telephone +49 241 8906-662 | petra.nolis@ilt.fraunhofer.de
Fraunhofer Institute for Laser Technology ILT | Steinbachstraße 15 | 52074 Aachen, Germany | www.ilt.fraunhofer.de

FRAUNHOFER INSTITUTE FOR LASERTECHNOLOGY ILT

of Extreme High-speed Laser Material Deposition EHLA. In the patented process, a laser melts the powder particles already above the melt pool. Thanks to this innovation, the process speed could be increased from the previous 0.5 to 2.0 (LMD) to up to 200 m/min and the coating thickness reduced from 500 to up to 10 μm . Up to five square meters can now be coated per hour. In addition, the coatings have become smoother, with roughness reduced to one tenth of the typical value for LMD.

February 2, 2023 || Page 2 | 7

International successes in rapid coating

The invention has caught on: Hornet Laser Cladding B.V. from Lexmond (Netherlands), for example, has integrated a laser beam source, EHLA processing head and powder-feed system into its lathes to use EHLA in industrial processes. TRUMPF Laser- und Systemtechnik GmbH, based in Ditzingen, Germany, also included the process in its portfolio of products and offers laser equipment and system technologies for the EHLA process. Among the first users are companies in the Netherlands, China, Germany and Turkey. The breakthrough came in 2015 for the offshore sector: Since then, many hundreds of meter-long hydraulic cylinders have been coated with wear- and corrosion-resistant alloys for worldwide use in maritime environments.

In 2019, the step into the third dimension followed after further successes in coating brake discs, pistons, cylinders and bearings fast and reliably. Jonathan Schaible, former research associate at Fraunhofer ILT, participated in the further development as part of his doctorate: He dealt with the question of which special requirements for machine and system technology must be met in order to combine EHLA with high-speed 3D printing. In parallel, his successor, Min-Uh Ko, has continued refining the process engineering on a specially modified five-axis CNC system that unites the highest precision with high feed rates for additive manufacturing, free-form coating and component repair using EHLA.

“EHLA 3D combines the productivity of LMD with its 500 to 2000 μm thick layers with the structurally targeted, precise buildup of LPBF with 30 to 100 μm thick layers,” explains Min-Uh Ko, the group leader of Additive Manufacturing and Repair LMD at the Fraunhofer Institute for Laser Technology ILT. “EHLA 3D is in the middle range with 50 to 300 μm .”

Close to the final contour

The low dilution zone and the high cooling rate also speak in favor of the process. Thanks to these properties, components made of materials that are difficult to weld and multi-material pairings can also be produced additively. The process shows its strengths in real 3D printing. Scientist Ko explains: “With EHLA 3D, it is possible to

FRAUNHOFER INSTITUTE FOR LASERTECHNOLOGY ILT

productively manufacture components that already come very close to the final contour. In addition to so-called near-net shaping, the process also makes it possible to build fast and precisely, as well as apply coatings on free-form surfaces.”

February 2, 2023 || Page 3 | 7

Complex forms in record time – This is only possible with appropriately designed machine technology and adapted path planning of the CNC programs. Productivity sinks or swims here as the so-called fly-in – when the laser head accelerates to the point of use with the laser beam switched on – interacts with the subsequent fly-out – when it decelerates out of the processing zone. The efficiency results from the ratio of the processing time with the laser beam switched on to the total process time. Schaible’s investigations prove this: At an acceleration of 50 m/s² and a feed rate of 50 m/min for a distance of 100 mm, the efficiency M-PDE (machine-related powder deposition efficiency) is around 80 percent. At an acceleration of 10 m/s², the M-PDE is approx. 40 percent.

The institute’s effort to further develop the EHLA process has paid off, as a look at the first successful demonstrations proved. At the “AKL’22 - International Laser Technology Congress” in Aachen, Germany, scientist Ko showed the current progress of the EHLA 3D technology during his presentation in spring 2022. For example, a video demonstrated the productive, additive manufacturing of a forming tool whose printing time could be reduced by a factor of two compared to LMD. In addition, further advantages result from the reduction in the effort required for finish machining.

Reliable 3D metal printing with used powder

The process is also characterized by high efficiency: Components made of the aerospace material Inconel 718 were 3D printed on the five-axis CNC system at a deposition rate of more than 2 kg/h with a density of over 99.5 percent. The Aachen researchers also investigated how the characteristic values change when they work with recycled metal powder instead of new. In both cases, the tensile strength R_m was around 1300 MPa. Ko explains: “In both cases the tensile strength turned out to be just as good as with casting.” Good results were also obtained by scientist Schaible, whose work included EHLA 3D process development of components made of 316L stainless steel and aluminum-silicon alloys. Here, too, the mechanical properties obtained are in line with those reported in the literature for conventionally produced samples. The currently possible structural resolution of thin-walled aluminum components produced using EHLA 3D is around 500 μm .

The CNC system located at Fraunhofer ILT is a specially adapted prototype that can move the tool in a reliable, precise and at the same time highly dynamic manner. Ko invites interested parties to look a little closer: “If you are interested in this plant

FRAUNHOFER INSTITUTE FOR LASERTECHNOLOGY ILT

technology or other possible uses for the EHLA 3D process, I will be happy to help here at Fraunhofer ILT.”

February 2, 2023 || Page 4 | 7

Talk to our experts at LASER World of PHOTONICS, Fraunhofer joint booth 441 in hall A3!



Image 1:
Min-Uh Ko, group leader of Additive Manufacturing and Repair LMD at Fraunhofer ILT: “EHLA 3D combines the productivity of LMD with its 500 to 2000 μm thick layers with the structurally targeted, precise buildup of LPBF with 30 to 100 μm thick layers.”
© Fraunhofer ILT, Aachen, Germany.



Image 2:
Jonathan Schaible, former research assistant at Fraunhofer ILT: “In the near future, even complex, filigree structures should be able to be produced easily and cost-effectively on a large scale using EHLA 3D. Individualized components will then also be conceivable.”
© Fraunhofer ILT, Aachen, Germany.

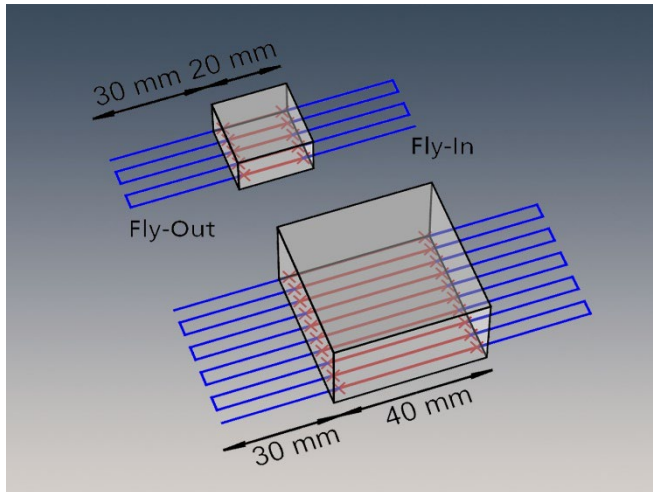

Image 3:
High dynamics: With EHLA 3D, productivity sinks and swims with the interaction of fly-in and fly-out.
© Fraunhofer ILT, Aachen, Germany.

February 2, 2023 || Page 5 | 7



Image 4:
Fast and precise: Using the example of a molded part additively manufactured with EHLA 3D, the institute demonstrated that it could significantly reduce printing time compared to LMD and LPBF.
© Fraunhofer ILT, Aachen, Germany.

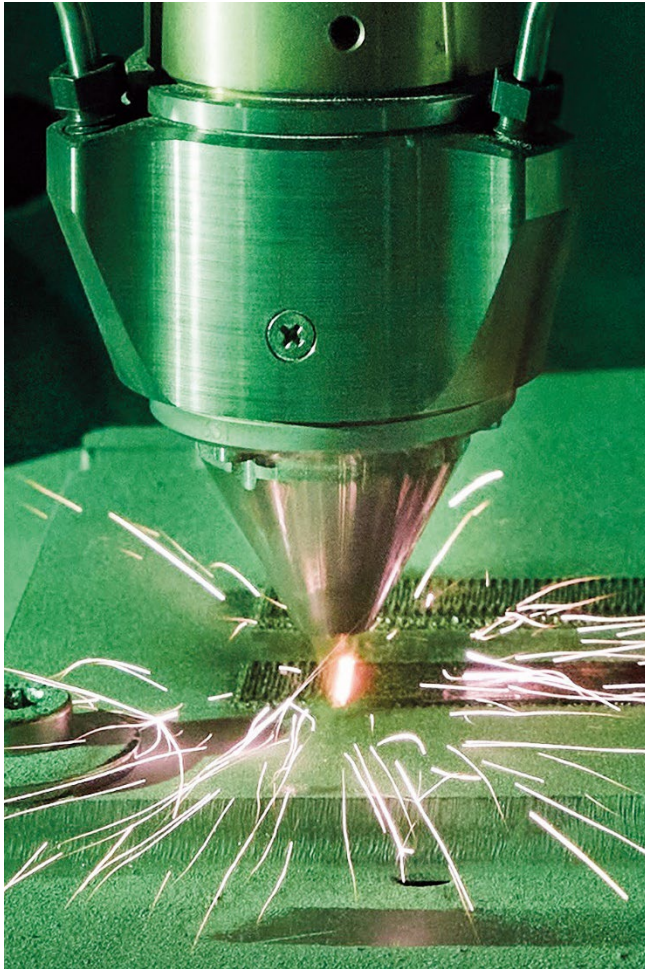

Image 5:
3D metal printing in record time: The CNC machine modified for the EHLA process can move tools in a fast, highly dynamic and precise manner in a lateral direction. With a rotary and tilting table, it is suitable not only for additive manufacturing, but also for free-form surface coatings.
© Fraunhofer ILT, Aachen, Germany.

FRAUNHOFER INSTITUTE FOR LASERTECHNOLOGY ILT**Professional contact**

February 2, 2023 || Page 7 | 7

Min-Uh Ko M. Sc.

Head of the Additive Manufacturing and Repair LMD Group
Telephone +49 241 8906-8441
min-uh.ko@ilt.fraunhofer.de

Fraunhofer Institute for Laser Technology ILT
Steinbachstraße 15
52074 Aachen, Germany
www.ilt.fraunhofer.de

The **Fraunhofer-Gesellschaft** based in Germany is the world's leading applied research organization. Prioritizing key future-relevant technologies and commercializing its findings in business and industry, it plays a major role in the innovation process. A trailblazer and trendsetter in innovative developments and research excellence, it is helping shape our society and our future. Founded in 1949, the Fraunhofer-Gesellschaft currently operates 76 institutes and research units throughout Germany. Over 30,000 employees, predominantly scientists and engineers, work with an annual research budget of €2.9 billion. Fraunhofer generates €2.5 billion of this from contract research.